

HANDRAIL - PWPS-HR-36-YL

APPROX WEIGHT: 32.48 lbs.
DOES NOT INCLUDE WEIGHT OF POWER OR PACKAGING!!!

ANY ADDITIONS, DELETIONS, OR OMISSIONS MUST BE CORRECTED ON THIS DRAWING AS THIS DRAWING WILL BE CONSIDERED ALL INCLUSIVE

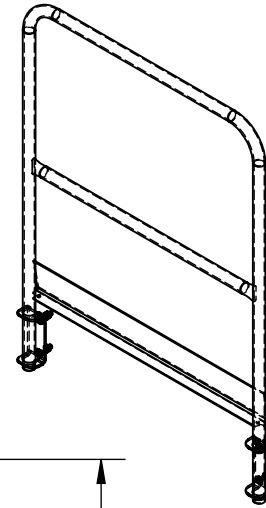
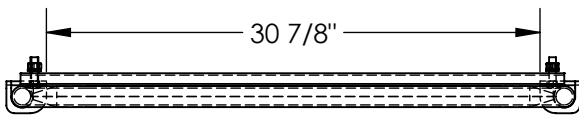

Ø 1 5/16"

SHOWN FOR REFERENCE ONLY

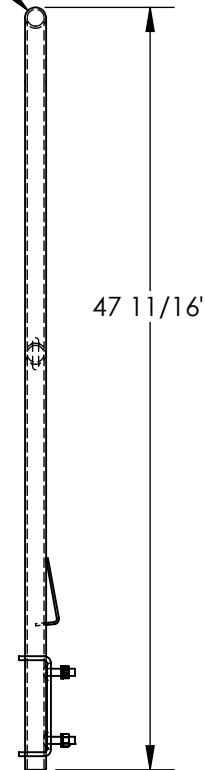
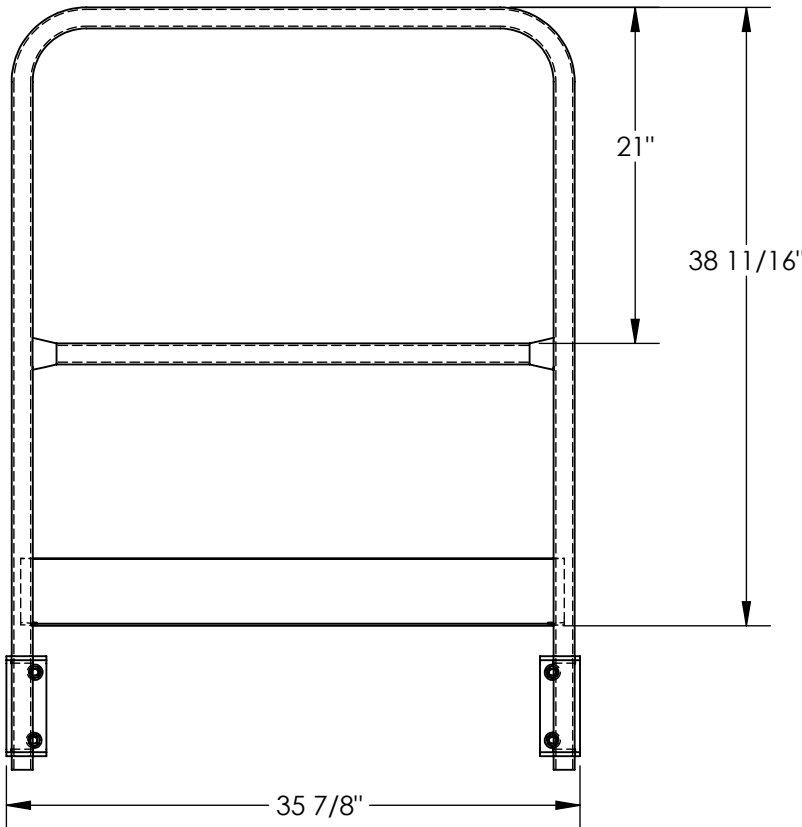

ALL GRAPHICS PROVIDED ARE FOR REFERENCE ONLY. IF CERTAIN DIMENSIONS ARE CRITICAL PLEASE VERIFY THOSE DIMENSIONS WITH YOUR SALESPERSON

DIMENSION TOLERANCE ± 1/4"

STANDARD FEATURES

MODEL NUMBER IS PWPS-HR-36-YL
HANDRAIL WITH TOEBOARD
BOLT-ON INSTALLATION
ATTACHES TO ONE SIDE OF PLATFORM
OVERALL HEIGHT 47 11/16"
OVERALL WIDTH 35 7/8"

HANDRAIL IS TOUGH BAKED IN POWDER COATED YELLOW FINISH

MOUNTING BRACKET IS TOUGH BAKED IN POWDER COATED BLACK FINISH

PWPS-HR INCLUDES
-1 HANDRAIL
-2 MOUNTING BRACKETS
- BRACKET MOUNTING HARDWARE

SPECIAL FEATURES

NONE

APPROVAL

I, THE UNDERSIGNED, AGREE THAT THE PRODUCT AS REPRESENTED SATISFIES DESIGN AND DIMENSION REQUIREMENTS. I ALSO ACKNOWLEDGE MY DUTY TO CONFIRM PRODUCT AND INSTALLATION COMPLIANCE WITH ALL APPLICABLE FEDERAL, STATE AND LOCAL REGULATIONS AND STANDARDS.
UNITS REQUIRING APPROVAL DRAWINGS OR MODIFIED ARE NON-RETURNABLE
[] As drawn [] As marked

Signed: _____ Date: _____

Printed Name: _____

LEAD TIME WILL START UPON RECEIPT OF SIGNED APPROVAL DRAWING

DISTRIBUTOR'S NAME:		P.O.#
VESTIL MANUFACTURING		X
DRAWN BY: WHR		DATE: 03/27/12
REFERENCE: X		SALES: X
QUOTED LEAD TIME: X		SCALE: 1:12
QUOTE # X		FILE NAME: 44-007-338